



National Power Corporation
INVITATION TO BID
SMALL VALUE PROCUREMENT 2023-005

1. The **NATIONAL POWER CORPORATION (NPC)**, through its approved Corporate Budget of **CY 2023** intends to apply the sum of (**Please see schedule below**) being the Approved Budget for the contract (ABC) to payments under the contract listed below. Bids received in excess of the ABC shall be automatically rejected at Bid opening.

	Ref. Nos./ PR Nos.	Description	Bid Submission/ Opening	ABC of the Project
1	MG-A5T23-009 SVP2023-AG5-016	SUPPLY AND DELIVERY, INSTALLATION, TEST & COMMISSIONING OF WATER TREATMENT FACILITY AT NPC NANGKA, BALO-I, LANA DEL NORTE & BARANGAY DITUCALAN, ILIGAN CITY, 60 CAL.DAYS	JULY 31, 2023 1:30PM	Php497,951.60
2	MG-A5M23-073 SVP2023-AG5-017	AG5 CONSTRUCTION OF STEEL STAIRWAY GOING TO SWITCHYARD AT NPC AGU5 5 HPP, DITUCALAN, ILIGAN CITY, 60 CAL. DAYS	JULY 31, 2023 1:30PM	Php830,768.37
3	MG-ST23-020 SVP2023-SSD-018	REPAIR AND REPAINTING OF EXISTING GUARD POST AT MARIA CRISTINA, ILIGAN CITY, 35 CAL. DAYS	JULY 31, 2023	Php599,565.88
4	MG-A5T23-010 SVP2023-AG5-019	CONSTRUCTION OF HAZARDOUS WASTE STORAGE FACILITY AT AGUS HPP, BARANGAY DITUCALAN, ILIGAN CITY, 60 CAL. DAYS	JULY 31, 2023 1:30PM	PhP1,000.000.00
5	MG-IPP23-012 SVP2023-IPP-020	SUPPLY OF LABOR, MATERIALS AND EQUIPMENT FOR THE REPAIR AND MAINTENANCE OF BUILDING (HOUSING QUARTER NO.28B) NPC COMPOUND, DITUCALAN, ILIGAN CITY, 50 CAL. DAYS	JULY 31, 2023 1:30PM	Php799,988.37
6	MG-CEN23-007 SVP2023-CMT-021	REPAIR OF NPC HOUSING UNITS NO.28A & 28A BASEMENT, NPC COMPOUND, BARANGAY DITUCALAN, ILIGAN CITY, 60 CALENDAR DAYS	JULY 31,2023 1:30PM	Php999,998.87
7	MG-ADM23-036 SVP2023-ADM-022	REPAIR OF TRANSFORMER SHED, NPC COMPOUND, DITUCALAN, ILIGAN CITY, 30 CAL. DAYS	JULY 31, 2023 1:30PM	Php216,000.00

2. NPC now invites Bids for Items listed above. Delivery of the Items are required within the contract period specified in the Technical Specifications. The Bidder must have completed a single contract that is similar to this Project, equivalent to an amount as stated in the Request for Quotation.
3. Bidding will be conducted through open competitive bidding procedures using a non-discretionary "pass/fail" pursuant to RA 9184 and its Revised IRR.
4. Interested bidders may obtain further information from the **BAC Secretariat, Contracts Management Office, Logistics Division** at the address given below during office hours, 8:00 AM to 5:00 PM Monday to Friday. A complete set of Request for Quotation (RFQ) may be secured by interested bidders free of charge from the address below.

It may also be downloaded free of charge from the website of the Philippine Government Electronic Procurement System (PhilGeps) <https://www.philgeps.gov.ph/> or the website of National Power Corporation <https://www.napocor.gov.ph/BCSD/bids.php>

5. Bids must be delivered to the address below on or before the date stated above. Late bids shall not be accepted.
6. NPC reserves the right to accept or reject any bid, to annul the bidding process, and to reject all bids at any time prior to contract award, without thereby incurring any liability to the affected Bidder or Bidders.
7. For further information, please refer to:

BAC SECRETARIAT
Contracts Management Office, Logistics Division
NPC Mindanao Generation
Maria Cristina, Iligan City
Tel. No.: (063) 222-3459
Fax No.: (063) 223-4604
E-mail Add.: logistics_afd_mingen@napocor.gov.ph

REYMANTE T. CIRUELA
Chairman, Bids and Awards Committee
Mindanao Generation Headquarters

Date of Publication: **July 22, 2023**

PROJECT HIGHLIGHTS

PH-1.0 GENERAL

This project aims to address the audit findings and recommendation of the safety committee that the current concrete stairway going to switchyard is very difficult to access during emergency due to its high degrees to climb and unsafe to the employee. The adverse condition is observe due to the complain during our monthly SHE meeting of the Agus 4&5 HPCC.

PH-2.0 PROJECT LOCATION

The project is located at NPC Agus 5 HP Plant, Brgy. Ditucalan, Iligan City

PH-3.0 SCOPE OF WORK

The work and services to be performed by the Contractor for this undertaking shall essentially consist of, but not limited to the following: (SEE WORK SCOPE INDICATOR on PLAN)

1. **CONSTRUCTION SAFETY & HEALTH PROGRAM**
2. **MATERIALS TESTING** (if necessary)
3. **SITE CLEARING AND PREPARATION**
 - a. Removal/Cutting Trees affected on the site area
 - b. Lay-outing and staking
4. **EXCAVATION WORKS**
 - a. Platforms and Pedestal
5. **CONCRETE WORKS**
 - a. Concrete Platform
 - b. Tall Post Pedestal
6. **MASONRY WORKS**
 - a. Fabrication of Steel Structure
7. **PAINTING WORKS**
 - a. Painting of Steel Structure excld. 16mm dia. gratings
8. **Demobilization including clearing of site/demolition of Contractor's camp facilities**

PH-4.0 CONTRACT PERIOD

The contractor shall complete the works as specified within Sixty (60) calendar days. The total contract duration is inclusive of six (6) unworkable days considered unfavorable for the execution of work at site. The contract period shall be reckoned from the date of contract effectivity as specified in the Notice to Proceed

PH-5.0 CONTRACTOR'S CLASSIFICATION

The contractor must have a valid Philippine Contractor's Accreditation Board (PCAB) license of at least **Category C or D – General Building** with inter-agency registration of at least **Small B – General Building - Industrial Plant** .

PHASE 3 REQUIREMENTS

Construction documents shall be prepared in accordance with the provisions of the contract documents. The construction documents shall include all items listed in the schedule of values. The construction documents shall be submitted to the architect for review and approval. The construction documents shall be submitted to the architect in accordance with the schedule of values. The construction documents shall be submitted to the architect in accordance with the schedule of values.

PHASE 4 REQUIREMENTS

The contractor shall be responsible for the coordination of all construction activities. The contractor shall be responsible for the coordination of all construction activities. The contractor shall be responsible for the coordination of all construction activities. The contractor shall be responsible for the coordination of all construction activities. The contractor shall be responsible for the coordination of all construction activities.

The contractor shall be responsible for the coordination of all construction activities. The contractor shall be responsible for the coordination of all construction activities. The contractor shall be responsible for the coordination of all construction activities. The contractor shall be responsible for the coordination of all construction activities. The contractor shall be responsible for the coordination of all construction activities.

The contractor shall be responsible for the coordination of all construction activities. The contractor shall be responsible for the coordination of all construction activities. The contractor shall be responsible for the coordination of all construction activities. The contractor shall be responsible for the coordination of all construction activities. The contractor shall be responsible for the coordination of all construction activities.

PHASE 5 REQUIREMENTS

The contractor shall be responsible for the coordination of all construction activities.

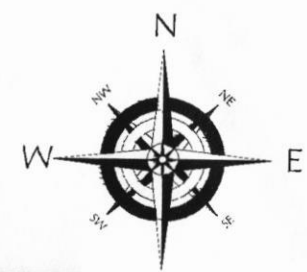

LOCATION MAP
SCALE NTS



VICINITY MAP
SCALE NTS



NATIONAL POWER CORPORATION
Mindanao Generation
AGUS 5 HEP

PROJECT: **AG5 CONSTRUCTION OF STEEL STAIRWAY GOING TO SWITCHYARD** SHEET NO.

LOCATION:

PREPARED:

L.G. NANGAS

Plant Manager, Agus 5 HEP

SUBMITTED:

E.H.C. MADRIO

Plant Operation Manager, Agus 5 HEP

ATTY. EDGAR L. RAMIREZ

OIC Vice President, MinGen

RECOMMENDED:

D.B. ESMADÉ

Plant Manager, Agus 4 & 5 HEP

APPROVED:

	BY	CHKD	DATE	PARTICULARS :	1 4
DESIGNED					
DRAWN					
REVIEWED	PRINCIPAL ENGR. / ARCH'T.				
CIVIL / ARCH'T					
ELEC.					
MECH.					DWG



LOCATION MAP



STEEL MILL



NATIONAL BUREAU OF INVESTIGATION
WASHINGTON, D. C. 20535

AGENCY INSTRUCTIONS
GOING TO STEEL MILL

[Handwritten signature]
Special Agent in Charge

WILLIAM J. RAVENHILL

1

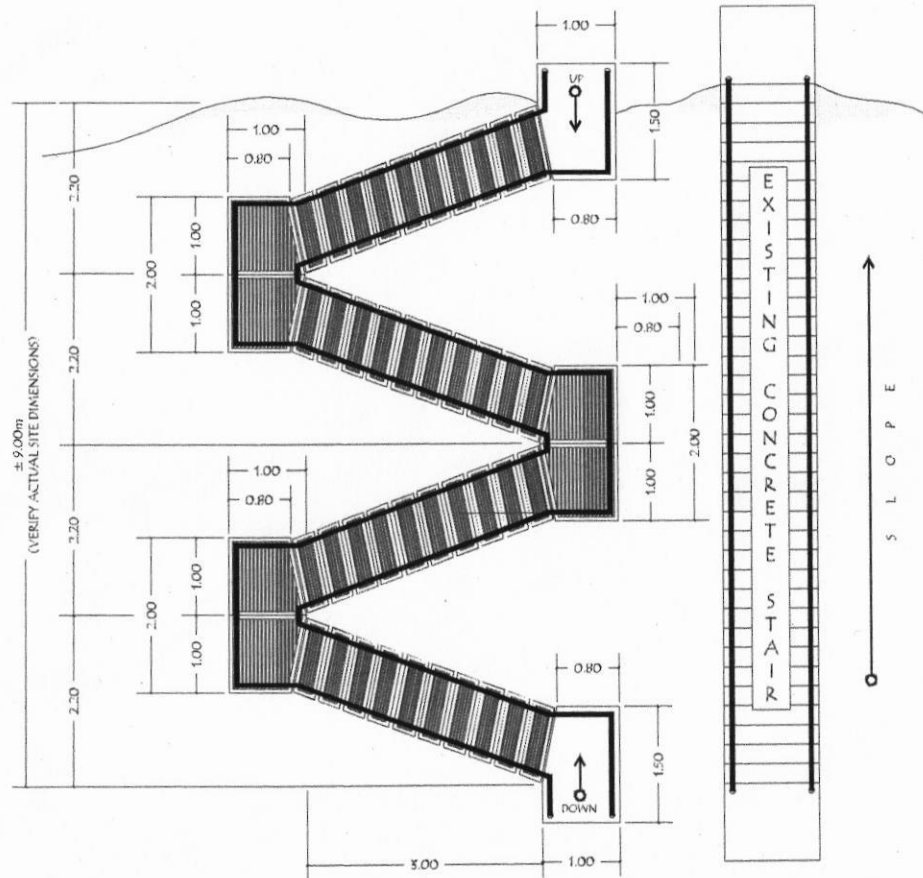

TYPICAL STEEL STAIR PLAN
SCALE: 1:100

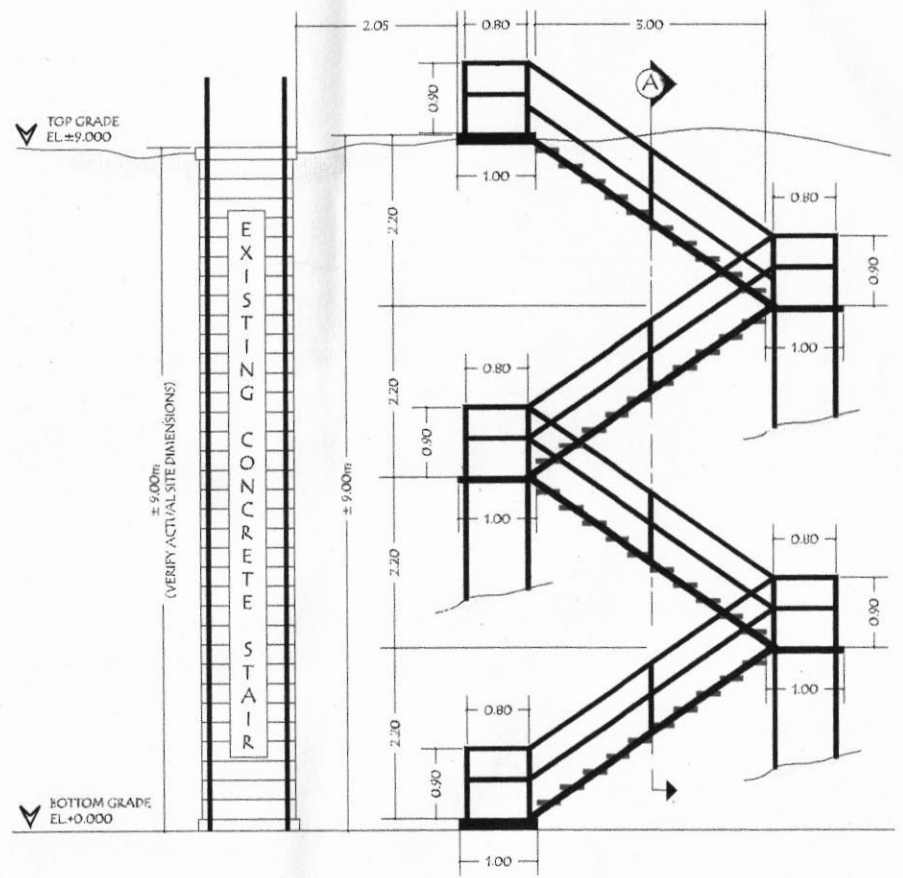

TYPICAL STEEL STAIR ELEVATION
SCALE: 1:100



NATIONAL POWER CORPORATION
Mindanao Generation
AGUS 5 HEP

PROJECT: **AG5 CONSTRUCTION OF STEEL STAIRWAY GOING TO SWITCHYARD**

SHEET NO.

LOCATION:

PREPARED:

L.G. NANGCAS
Mnfr. L. Foreman, Agus 5 & 5 HEP

SUBMITTED:

E.H.C. MADRIO
Plant Operator Manager, Agus 5 HEP

RECOMMENDED:

D.B. ESMADÉ
Plant Manager, Agus 4 & 5 HEP

APPROVED:

ATTY. EDGAR L. RAMIREZ
OIC Vice President, MinGen

DESIGNED	BY	CHKD	DATE	PARTICULARS:
DRAWN				
REVIEWED	PRINCIPAL ENGR. / ARCH'T.			
CIVIL / ARCH'T				
ELEC				
MECH.				

2
4

DWG

100-100000

City of New York, New York

OFFICE OF THE CITY ENGINEER



100-100000



NATIONAL POWER CORPORATION

100-100000

100-100000

NO.	DATE	REVISION

GOING TO

STEELEMAN

STEEL STAIRWAY

NATIONAL POWER CORPORATION

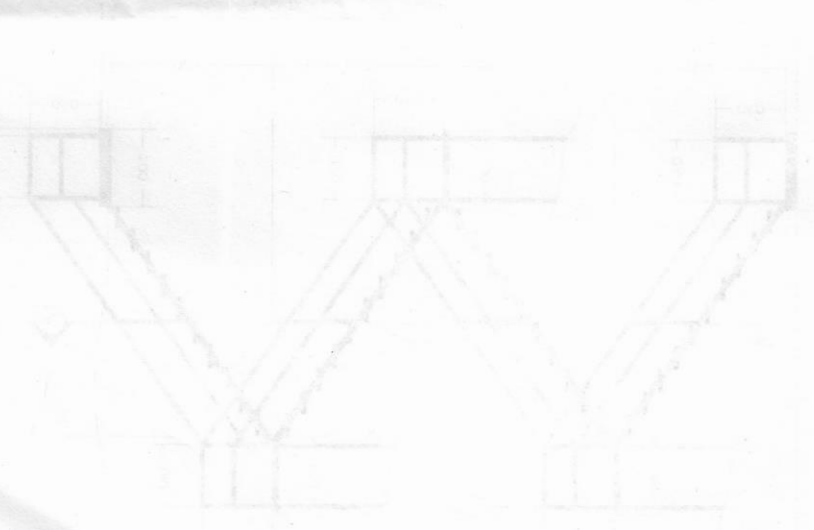
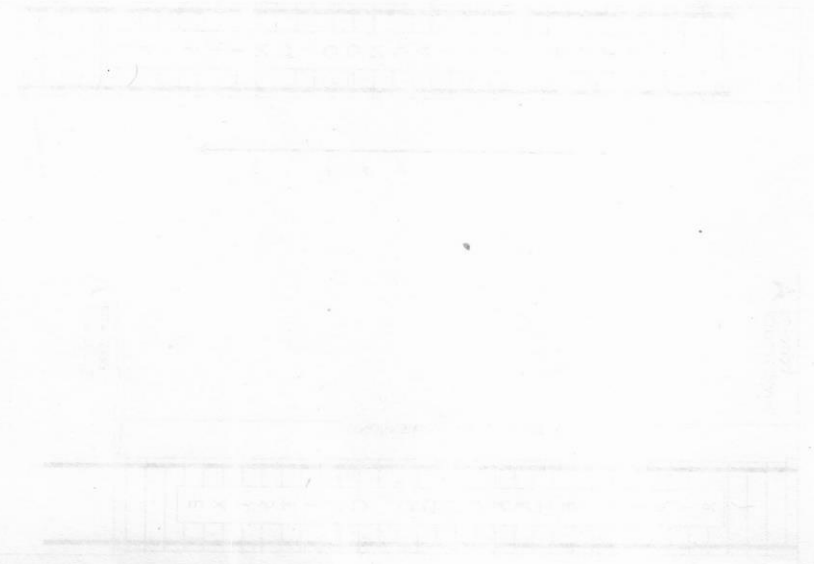
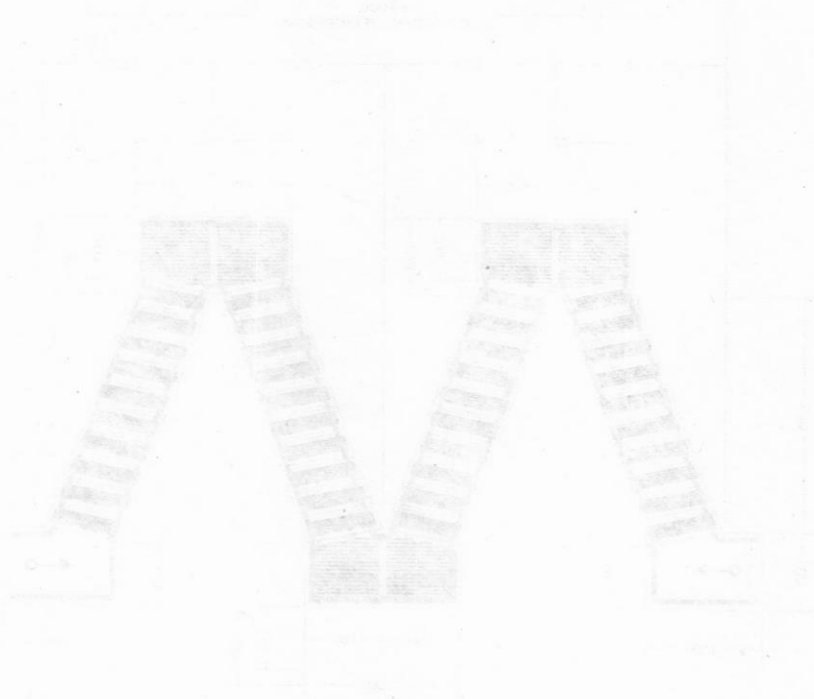

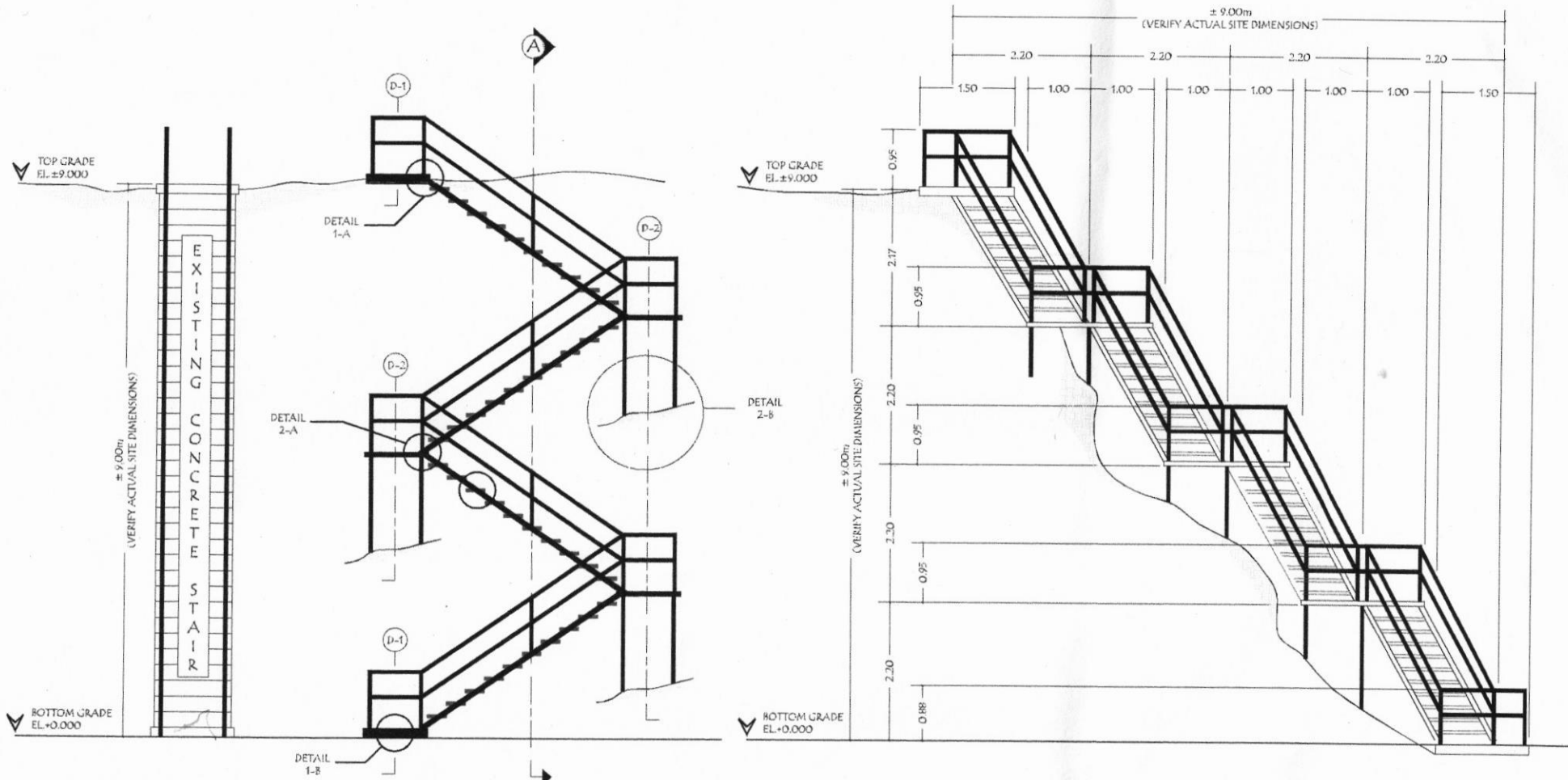

STEEL STAIR DETAILS
SCALE: 1:100

STEEL STAIR SECTION
SCALE: 1:100



NATIONAL POWER CORPORATION
Mindanao Generation
AGUS 5 HEP

PROJECT: **AG5 CONSTRUCTION OF STEEL STAIRWAY GOING TO SWITCHYARD** SHEET NO.

LOCATION:				PARTICULARS:
DESIGNED	BY	CHKD	DATE	
DRAWN				3
REVIEWED	PRINCIPAL ENGR. / ARCH'T.			
CIVIL / ARCH'T				4
ELEC.				
MECH.				DWG

PREPARED: **L.G. NANGCAS**
Main Foreman, Agus 4 & 5 HEPC

RECOMMENDED: **D.B. ESMADÉ**
Plant Manager, Agus 4 & 5 HEPC

SUBMITTED: **E.H.C. MADRIO**
Plant Operations Manager, Agus 5 HEP

APPROVED: **ATTY. EDGAR L. RAMIREZ**
OIC Vice President, MinGen



NATIONAL POWER CORPORATION

MANILA OFFICE

August 21, 1951

STAIR SECTION



STAIR SECTION

GOING TO
STAIRWAY

3

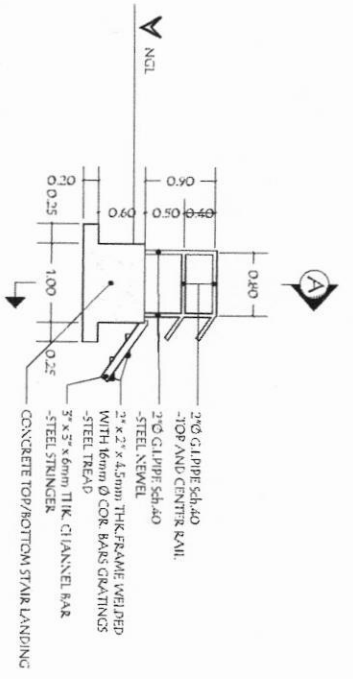

D-1 TOP & BOTTOM CONCRETE STAIR LANDING
SCALE: 1:50

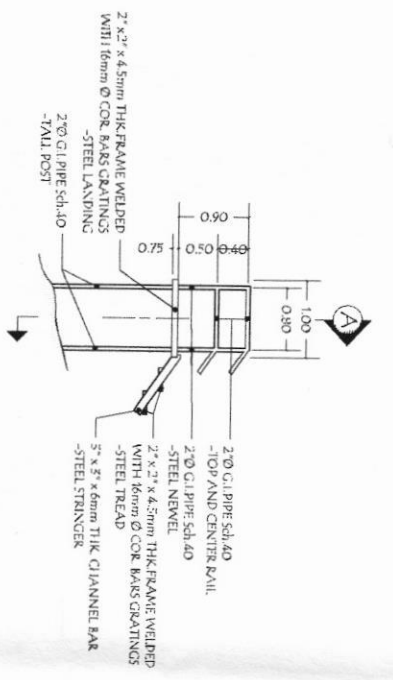

D-2 1st - 5th STEEL STAIR LANDING
SCALE: 1:50

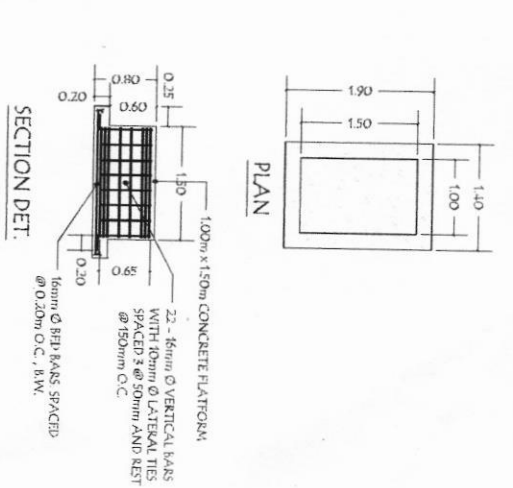

D-3 CONCRETE PLATFORM DETAIL
SCALE: 1:50

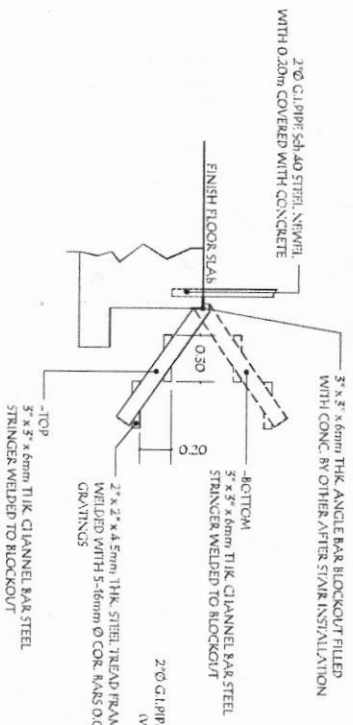

D-4 STAIR TOP/BOTTOM CONNECTION TO CONC. SLAB EDGE
SCALE: 1:50

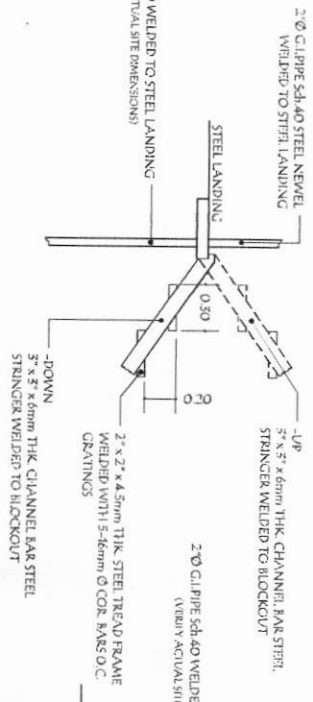

D-5 STAIR CONNECTION TO STEEL LANDING EDGE
SCALE: 1:50

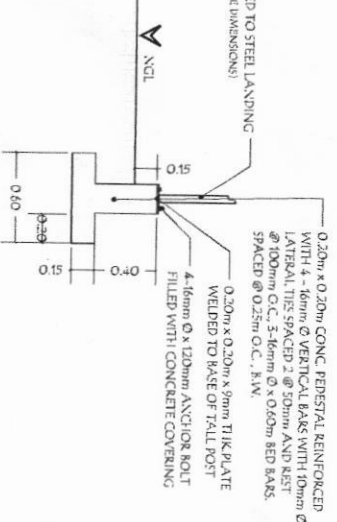

D-6 CONNECTION ATTACH TO CONCRETE PEDESTAL
SCALE: 1:50



NATIONAL POWER CORPORATION
Mindanao Generation
AGUS 5 HEP

AG5 CONSTRUCTION OF STEEL STAIRWAY GOING TO SWITCHYARD

PROJECT:	AG5 CONSTRUCTION OF STEEL STAIRWAY GOING TO SWITCHYARD			SHEET NO.	4
LOCATION:	BY	CHKD	DATE	PARTICULARS:	
	DESIGNED				
	DRAWN				
	REVIEWED	PRINCIPAL ENGR. / ARCH-T.			
	CIVIL / ARCH-T				
	ELEC				
	MECH				

PREPARED: **D.G. NANEAGAS**
Major, Mechanical, Agus 5 & 7 HEP

SUBMITTED: **ERIC MADRID**
Plant Operator, Agus 5 HEP

RECOMMENDED: **D.B. ESMARDE**
Plant Manager, Agus 4 & 5 HEP

APPROVED: **ATTY. EDGAR L. RAMIREZ**
OIC Vice President, MindGen

DWG

SECTION VIII - BILL OF QUANTITIES

Name of Project

AG5 CONSRUCTION OF STEEL STAIRWAY
GOING TO SWITCHYARD
MG-A5M23-073

PR #

BILL OF QUANTITIES

Item No.	Description of Work or Materials	Unit	Estimated Quantity	Unit Price in Pesos (Words and Figures)	Total Amount
1	CONSTRUCTION OF SAFETY & HEALTH PROGRAM	1.00	Lot	_____	_____
2	SITE CLEARING AND PREPARATION			_____	_____
	A Removal / Cutting Trees affected on site area	1.00	Lot	_____	_____
	B Lay-outing and Staking	1.00	Lot	_____	_____
3	EXCAVATION WORKS			_____	_____
	A. Excavation - Flatforms and Pedestals	3.85	Cu.m.	_____	_____
4	CONCRETE WORKS			_____	_____
	A. Tall Post Pedestal	3.47	Cu.m.	_____	_____
	B Tall Post Pedestal	0.84	Cu.m.	_____	_____
5	Fabrication of Steel Steel Structure			_____	_____
	A. Fabrication of Steel Steel Structure	1,688.62	Kls.	_____	_____
6	PAINTING WORKS			_____	_____
	A. Painting of Steel Structure excld. 16mm Ø gratings	1.00	Lot	_____	_____

Name and Signature of Authorized Representative

Designation

1. Name of the Project: _____

2. Location: _____

3. Date: _____

4. Name of the Investigator: _____

5. Title of the Report: _____

6. Name of the Institution: _____

7. Address: _____

8. Telephone: _____

9. Fax: _____

10. E-mail: _____

11. Website: _____

12. Other: _____

13. Name of the Sponsor: _____

14. Address: _____

15. Telephone: _____

16. Fax: _____

17. E-mail: _____

18. Website: _____

19. Other: _____

20. Name of the Project: _____

21. Location: _____

22. Date: _____

No. Item	Description of Work or Purpose	Start Date	End Date	Remarks and Files	Cost Files in Fee
1	CONDUCT OF RESEARCH AND FIELD SURVEY	1999	2000		
2	ANALYSIS OF DATA	2000	2001		
3	PREPARATION OF REPORT	2001	2002		
4	REVISION OF REPORT	2002	2003		
5	FINAL REPORT	2003	2004		
6	ARCHIVAL OF DATA	2004	2005		
7	OTHER				
8	OTHER				
9	OTHER				
10	OTHER				
11	OTHER				
12	OTHER				
13	OTHER				
14	OTHER				
15	OTHER				
16	OTHER				
17	OTHER				
18	OTHER				
19	OTHER				
20	OTHER				

US # _____

Name of Project _____

FORMS-013
 U.S. DEPARTMENT OF AGRICULTURE
 NATIONAL AGRICULTURAL LIBRARY

2 / 3